

NAD SERVICE MANUAL

NAD 7175PE SERVICE MANUAL

NOTE: This manual covers all versions.

A: U.S.A.

A1: Canada

B: U.K.

B1: Australia

C: EUROPE and others

C1: W-Germany

TABLE OF CONTENTS	PAGE
LOCATION MAP	2
SPECIFICATION	3 - 5
INTERNAL VIEW	6
SUGGESTED INSTRUMENTATION HOOKUP	7
FM ALIGNMENTS	8 - 11
AM ALIGNMENTS	12 - 13
AMPLIFIER ALIGNMENTS	14
AMPLIFIER P.C.B. LAYOUT DIAGRAM	16 - 17
SCHEMATIC DIAGRAM (AMPLIFIER SECTION)	18 - 19
TUNER P.C.B. LAYOUT DIAGRAM	20 - 21
SCHEMATIC DIAGRAM (TUNER SECTION)	22 - 23
WIRING DIAGRAM	24 - 25
EXPLODED VIEW PARTS LIST	26 - 28
EXPLODED VIEW	29
ELECTRICAL PARTS LIST	30 - 34

7175PE

AM/FM RECEIVER

REAR PANEL

1. AC Line Cord.
2. AC Outlets (not in U.K. version).
3. Speakers A.
4. Speakers B.
5. Antenna Terminals.
6. AM Rod Antenna.
7. Phono Input.
8. Phono Ground.
9. MM/MC Selector.
10. Video Sound Input.
11. CD Input.
12. Tape 1 Rec/Play.
13. Tape 2 Rec/Play.
14. Preamp Out, Main In.
15. Soft Clipping.
16. Speaker Impedance.

LE PANNEAU ARRIERE

1. Cordon d'alimentation.
2. Prises CA.
3. Enceintes A.
4. Enceintes B.
5. Bornes d'antennes.
6. Antenne AM.
7. Entrée phono.
8. Masse phonolecteur.
9. Sélecteur de phonolecteur.
10. Vidéo.
11. Entrée lecteur de disque compact.
12. Entrée/Sortie magnétophone 1.
13. Entrée/Sortie magnétophone 2.
14. Sortie de préamplification.
15. Ecrêtage en douceur.
16. Impédance.

RÜCKSEITE

1. Netzkabel.
2. Sekundär-Steckdosen.
3. Anschlüsse für Lautsprechergruppe A.
4. Anschlüsse für Lautsprechergruppe B.
5. Antennen-Anschlüsse.
6. Mittelwellen (AM)-Ferritantenne.
7. Plattenspieler-Eingang.
8. Masseanschluß für Plattenspieler.
9. MM/MC Umschalter.
10. Video.
11. CD-Eingang.
12. Tonbandgerät 1 Eingang/Ausgang.
13. Tonbandgerät 2 Eingang/Ausgang.
14. Vorverstärker-Ausgang/Endverstärker-Eingang.
15. Impulsbegrenzungs-Schalter.
16. Lautsprecherimpedanz-Schalter.

ATTENTION:

AVERTISSEMENT
UN CHOC ÉLECTRIQUE
ET LES CONSÉQUENCES GRAVES QUI POURRAIENT EN RÉSULTER, NE TENTEZ PAS D'OUVRIR L'APPAREIL ET DE TOUCHER AUX COMPOSANTS INTERNES SANS LA PRÉSENCE D'UNE PERSONNE QUALIFIÉE.

CAUTION

RISK OF ELECTRIC SHOCK
DO NOT OPEN
CAUTION TO REDUCE THE RISK OF ELECTRIC SHOCK, DO NOT REMOVE COVER (OR BACK). NO USER-SERVICEABLE PARTS INSIDE. REFER SERVICING TO QUALIFIED SERVICE PERSONNEL.

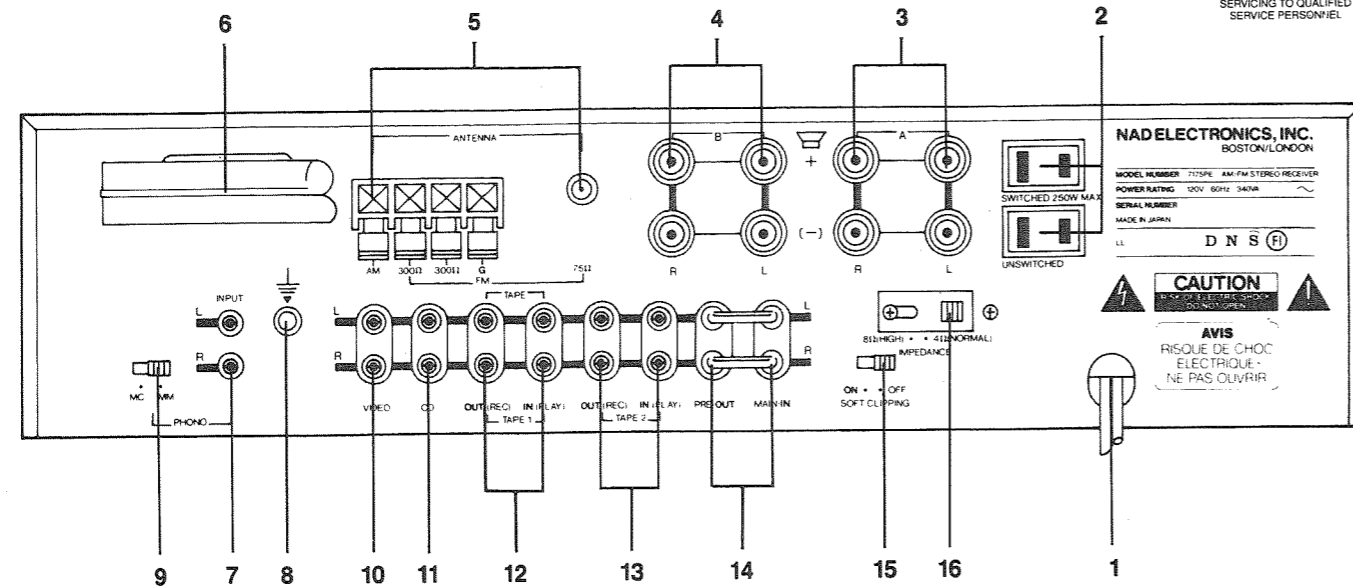

FRONT PANEL

1. Power.
2. Phones.
3. Speaker Selector.
4. Bass.
5. Treble.
6. Bass EQ.
7. Infrasonic Filter Off.
8. Mono.
9. FM NR Off.
10. Recording Input Selector.
11. Listen Input Selector.
12. Low Level.
13. Loudness Compensation.
14. Volume Balance.
15. Tuning Display.
16. Status Indicators.
17. Station Pre-sets.
18. Memory Enter.
19. AM / FM.
20. Up/Down Tuning.
21. Search.

LE PANNEAU AVANT

1. Alimentation.
2. Casque d'écoute.
3. Sélecteur d'enceintes.
4. Graves.
5. Aigus.
6. Bass EQ.
7. Filtre infrasonique.
8. Mono.
9. FM NR defeat.
10. Sélecteur de source d'enregistrement.
11. Sélecteur de source de lecture.
12. « Low level ».
13. Commutateur de contour sonore.
14. Volume/Équilibrage.
15. Affichage de la fréquence d'accord.
16. Témoins.
17. Touches de présélection.
18. Mémoire.
19. AM / FM.
20. Syntonisation électronique.
21. Touche de syntonisation.

FRONTSEITE

1. Netzschalter.
2. Kopfhörer-Anschluß.
3. Lautsprecher-Wahlschalter.
4. Baßsteller.
5. Höhensteller.
6. Baß Equalizer-Schalter.
7. Schalter für Infraschall-Filter.
8. Mono/Stereo-Schalter.
9. Stereo-Rauschminderung.
10. Aufnahme-Wahlschalter.
11. Wiedergabe-Wahlschalter.
12. Schalter für Lautstärkeabsenkung.
13. Gehörichige Lautstärke-Einstellung.
14. Lautstärke/Balance-Steller.
15. Abstimmanzeige.
16. Anzeigen für Betriebszustände.
17. Stationstasten.
18. Eingabebereitschaft für Stationstastenspeicher.
19. Wellenbereichsschalter für UKW/Mittelwelle.
20. Wippe zur Frequenzeinstellung.
21. Suchlauf.

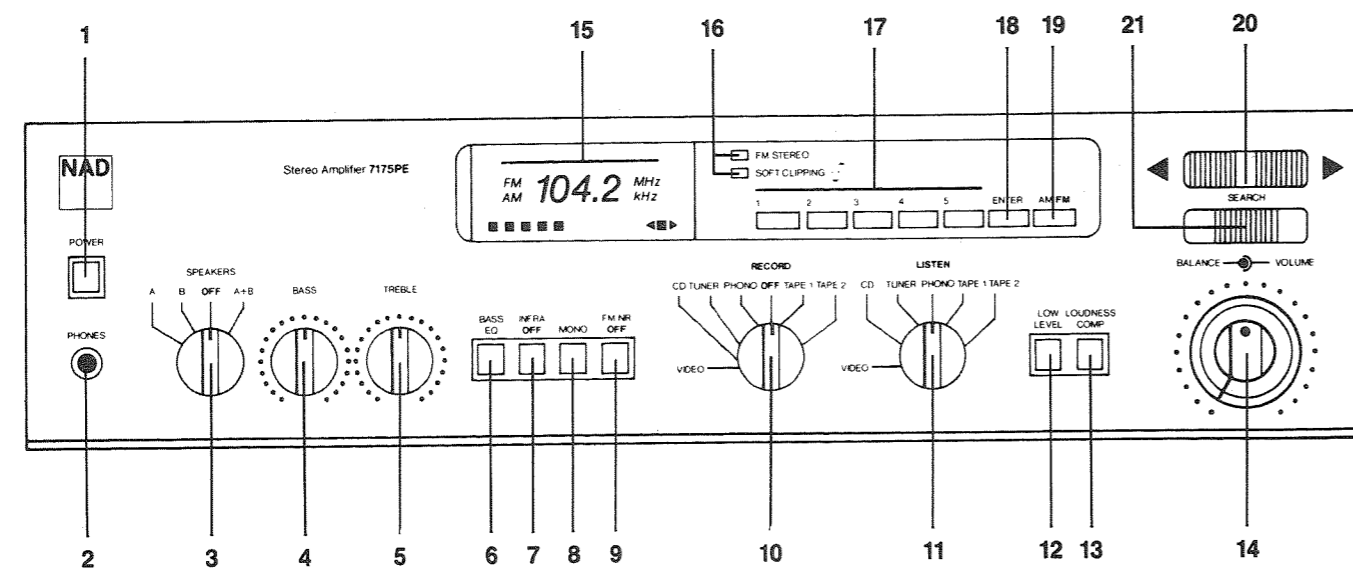

SPECIFICATIONS

NOTE: Measurements referenced to 8 ohms are taken with the Speaker Impedance Selector set to "8 ohm (High)". Measurements for 4 and 2 ohms are taken with the impedance selector at "4 ohm (Normal)". Specifications are measured in accordance with EIA Standard RS-490 (IHF A-202) for amplifiers and ANSI-IEEE Standard 185 (1975) (IHF T-200) for tuners. Tuner sensitivity is measured via 75 ohm coaxial input and converted to equivalent 300 ohm values.

POWER AMPLIFIER SECTION

CONTINUOUS AVERAGE POWER OUTPUT INTO 8 OHMS (min. RMS power per channel into 8 ohms, 20 Hz – 20 kHz, both channels driven, with no more than the rated distortion)	75 W (18.7 dBW)
Rated distortion (THD), 20 Hz – 20 kHz	0.03 %
Clipping power (max. continuous power per channel)	8 ohms 80 W
IHF dynamic headroom at 8 ohms	+6 dB
IHF dynamic power (max. short-term power per channel)	8 ohms 300 W 4 ohms 400 W 2 ohms 500 W
Peak output current (amperes)	> 40 A
Slew factor	> 50
Slew rate	30 V/μsec
Damping factor (ref. 8 Ω, at 50 Hz)	> 50
Input impedance	30 kΩ
Input sensitivity for 1 W/rated power	120 mV/1 V
Power amplifier gain	28 dB (25X)
THD (Total Harmonic Distortion, 20 Hz – 20 kHz, from 250 mW to rated output)	< 0.03 %
SMPTE I.M. (Intermodulation Distortion, 60 Hz + 7 kHz, 4:1, from 250 mW to rated output)	< 0.03 %
IHF I.M. (CCIF IM Distortion, 19 + 20 kHz at rated output)	< 0.03 %

PREAMPLIFIER SECTION

PHONO INPUT

Input impedance (MM or MC)		R = 47 k Ω ; C = 100 pF
Input sensitivity (ref. 1 watt)	MM:	0.4 mV
	MC:	0.03 mV
Input overload at 20 Hz/1 kHz/20 kHz	MM:	18 mV/170 mV/1.5 V
	MC:	1.5 mV/13 mV/110 mV
THD (20 Hz – 20 kHz) and IM Dist. at +30 dB level		< 0.04 %
RIAA response accuracy		± 0.5 dB
S/N ratio, IHF A-weighted, with cartridge connected	MM:	76 dB re 5 mV
	MC:	76 dB re 0.5 mV

LINE LEVEL INPUT (CD, Video, Tape)

Input impedance	R = 10 k Ω ; C = 220 pF
Input sensitivity (ref. 1 watt)	25 mV
Maximum input signal	> 10 V
Signal to noise ratio, A-weighted	86 dB re 1W > 100 dB ref. rated power
Frequency response, 20 Hz – 20 kHz	± 0.5 dB

OUTPUTS

Preamp out impedance	800 ohms
Maximum output level	10 V
Tape output impedance	1,000 ohms (buffered)
Tape output infrasonic filter	-3 dB at 15 Hz, 12 dB/octave

CONTROLS

Treble	± 7 dB at 10 kHz
Bass	± 7 dB at 100 Hz
Speaker Equalization	+3 dB at 70 Hz, +6 dB at 32 Hz
Infrasonic filter (switchable)	-3 dB at 15 Hz, 12 dB/octave
Audio muting (low level)	-20 dB

FM TUNER SECTION

Input sensitivity	Mono, -30 dB THD + N Mono, 50 dB S/N Stereo, 50 dB S/N Stereo 60 dB S/N	10.3 dBf (1.8 μ V/300 Ω , or 0.9 μ V into 75 Ω) 14.2 dBf (2.8 μ V) 29 dBf (15 μ V), FM NR on 36 dBf (35 μ V), FM NR off 40 dBf (55 μ V), FM NR on 46 dBf (110 μ V), FM NR off
Capture ratio (at 45 and 65 dBf)		< 1.5 dB
AM rejection (at 65 and 85 dBf)		> 65 dB
Selectivity	Alternate channel Adjacent channel	70 dB 8 dB
Image rejection		85 dB
R.F. intermodulation		70 dB
I.F. rejection		100 dB
SCA rejection		70 dB
Subcarrier suppression (19 & 38 kHz)		60 dB
THD at 100 % modulation		1 kHz 100 Hz – 6 kHz Mono 0.08 % 0.2 % Stereo 0.08 % 0.3 %
Signal-to-noise ratio A-weighted, 65 dBf	Mono Stereo	82 dB 76 dB (typ. 80 dB at 75 dBf)
Frequency response, 30 – 15 kHz		± 0.5 dB
Stereo separation (FM NR off)	1 kHz 30 Hz – 10 kHz	50 dB 40 dB

AM TUNER SECTION

Usable sensitivity	300 μ V/meter
THD	0.5 %
Selectivity	35 dB
Image rejection	50 dB
I.F. rejection	50 dB
S/N ratio (30 % mod., 50 mV input)	45 dB

PHYSICAL SPECIFICATIONS

Dimensions (width x height x depth)	42 x 10.8 x 38 cm. 16.5 x 4.25 x 15 in.
Net weight	9.18 kg./20 lb. 4 oz.
Shipping weight	10.6 kg./23 lb. 6 oz.
Power consumption (50/60 Hz at 110, 120, 220 or 240 VAC)	340 W

INTERNAL VIEW

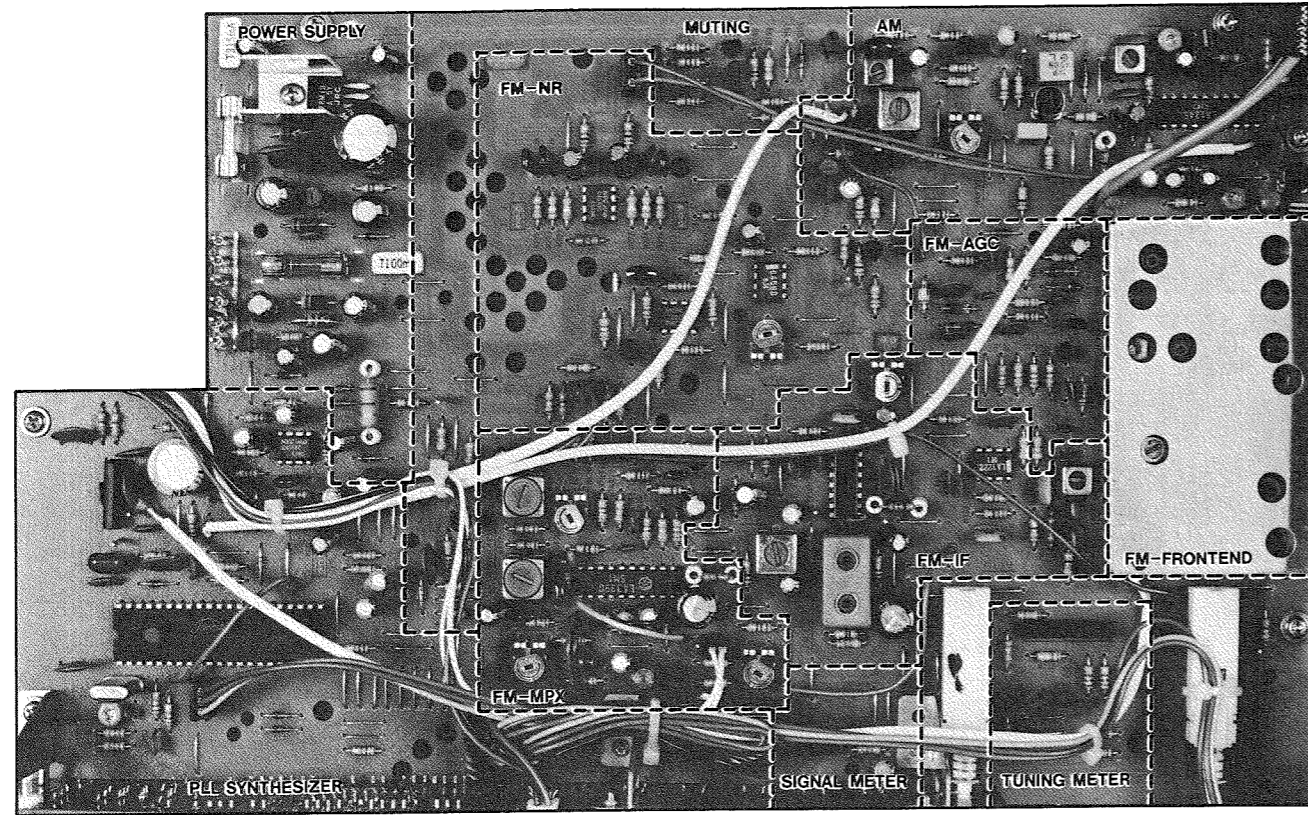

SUGGESTED INSTRUMENTATION HOOKUP

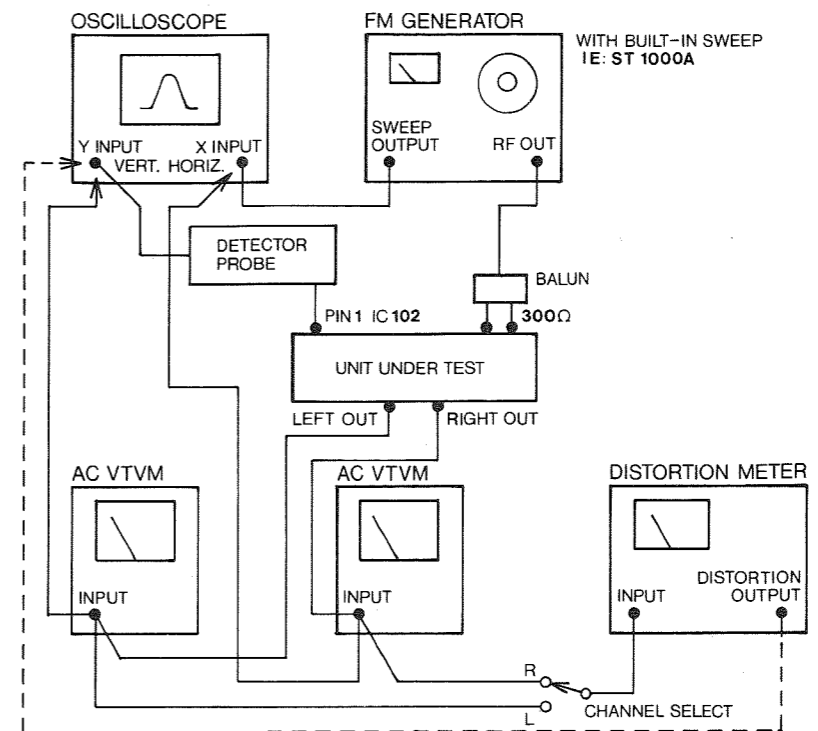
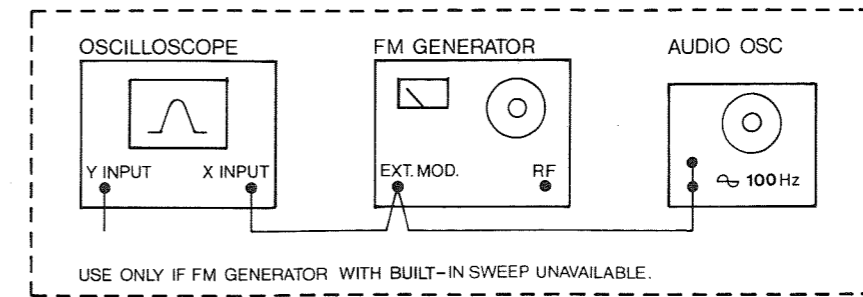

SCHEMATIC DIAGRAM OF DETECTOR PROBE

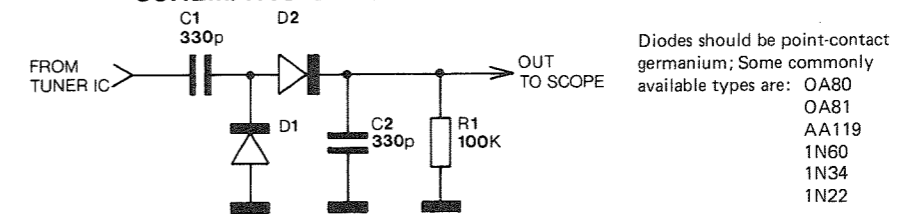

PICTORIAL DIAGRAM OF DETECTOR PROBE

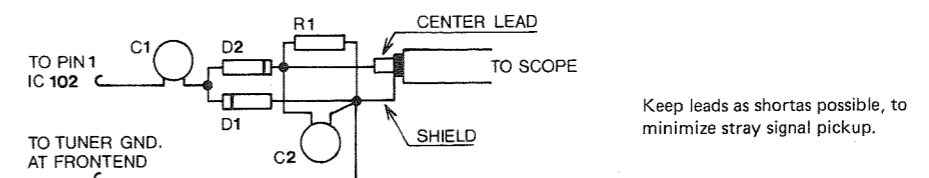

FM ALIGNMENTS

NECESSARY INSTRUMENTATION

FM GENERATOR (less than 0.05% THD)

STEREO GENERATOR (less than 0.05% THD, more than 50 dB sep.)

AUDIO GENERATOR (not necessary if FM generator has built in sweep; i.e., SOUND TECHNOLOGY ST 1000A and ST 1020A)

AC VTVM's (or one with a left/right switch)

THD ANALYZER (resolution less than 0.1%)

OSCILLOSCOPE (5mV or better sensitivity, X input capability)

FREQUENCY COUNTER

VOM or DMM (high impedance, must read in mV)

DETECTOR PROBE

IMPORTANT While all FM generator output levels hereafter are referred to the 300 ohm input, 75 ohm input can be used, but be aware of possible equipment groundloops and divide the RF output levels by 2.

Before alignments commence set input selector to tuner and release mono and FM NR OFF switches (out).

FRONTEND Alignment of frontend should only be necessary after repair to frontend or crystal oscillator circuits (pin 2 and 3 on IC 110).

A TUNING VOLTAGE (OSCILLATOR)

It is essential to check tuning voltage before aligning the rest of the frontend.

- 1 Connect DMM between ground and TP 102.
- 2 Tune to 108 MHz and adjust C 20 if voltage is incorrect.
SPECIFICATION $24.7V \pm 0.5V$
- 3 Tune to 88 MHz and read voltage. Adjust L 6 if voltage is incorrect.
SPECIFICATION $3.6V \pm 0.5V$
- 4 Repeat step 2 and 3 until readings are within tolerances.

B RF ADJUSTMENT (TRACKING)

- 1 Connect RF generator to 300 ohm antenna input and detectorprobe to pin 1 IC 102 with ground to tunershield. Adjust sensitivity of oscilloscope to maximum (5mV or better) and modulate FM generator sweep ± 300 kHz or more.
- 2 Set tuner to 105 MHz, enter into preset 5, and tune generator so that curve appears on oscilloscope. Turn down RF input level so that curve covers approximately 1/2 of oscilloscope display.
- 3 Adjust C 3, C 9, C 11 and C 15 to maximum curve height while reducing RF input to keep entire curve on display.
- 4 Set tuner to 90 MHz, enter into preset 1, and tune generator so that curve appears on oscilloscope display.
- 5 Adjust L 1, L 2, L 3 and L 4 to maximum curve height.
- 6 Repeat steps 2, 3, 4 and 5 (use preset 1 and 5) until both frequencies are at maximum curve height.

NOTE: 105 MHz curveheight is typically slightly stronger than 90 MHz.

C IF ADJUSTMENT

- 1 Set tuner to approximately 98 MHz (the tuner must be tuned to an unoccupied frequency) enter into preset 3, and tune FM generator to display a curve on oscilloscope.
- 2 Adjust L 5 and L 101 to maximum and symmetrical curve on the display, using as little input as possible.

NOTE: Maximum input 500 μV , typical curveheight 4 mV at 150 μV and 15 mV at 300 μV .

- D DETECTOR COARSE ADJUSTMENT (OPTIONAL, NEEDED ONLY IF DETECTOR WAS REPAIRED)**
- 1 Reduce sweep modulation level to ± 75 kHz and set input level to $300 \mu\text{V}$.
 - 2 Adjust FM generator frequency so that both legs of the inverted U-shaped curve are equally high on the display. The curve should be almost perfectly symmetrical.
 - 3 Disconnect detectorprobe from tuner and oscilloscope. Connect either of the tape 1 rec. outputs to the oscilloscope.
 - 4 The oscilloscope should now display a diagonal line. Adjust L 102 primary (closest to IC 102) to maximum curveheight and L 102 secondary to minimum curve height and straightest possible line. Go back and forth between primary and secondary till both are peaked.
- NOTE: Both the cores should be within 1.5mm from the top of the form.
- E DETECTOR ALIGNMENT (FINAL)**
- 1 Disconnect detectorprobe and connect tape 1 rec. output to VTVM's, oscilloscope and distortion analyzer.
 - 2 Switch stereo generator to 1 kHz 100% (± 75 kHz) mono modulation and oscilloscope to normal internal sweep 0.2 mS and 0.5 V/cm sensitivity.
 - 3 Detector reference frequency.
Reduce FM generator output level while monitoring THD from left channel. When THD increases to 3%, fine tune the FM generator frequency to minimum THD. Reduce FM generator output level and fine tune till no reduction in the 3% THD can be achieved by fine tuning. Use this frequency for all the following detector, MPX and FM NR adjustments.
NOTE: The typical input level for this 3% THD should be $1.6 \mu\text{V}$ to $2.3 \mu\text{V}$. This is done only to "line up" the frequency from the generator to the tuner's frequency.
If IHF usable sensitivity (-30 dB THD + N = 3.16%) is to be verified, a proper IHF bandpass-filter must be used.
 - 4 Connect DMM across TP 104 (negative) and TP 105 (positive). Set FM generator output to $1000 \mu\text{V}$
 - 5 Adjust L 102 primary (closest to IC 102) for 0 V on DMM.
TOLERANCE ± 50 mV
 - 6 Adjust L 102 secondary for lowest THD.
SPECIFICATION less than 0.1%
 - 7 Repeat steps 3, 5 and 6 till no further improvements. Record the DMM's final reading for use later in the adjustments. (I - 3)
- F AUTOSEARCH LEVEL**
- 1 Connect DMM between ground and TP 107.
 - 2 Increase FM generator level upwards from 0 and adjust R 107 "MUTE" so that DMM reading goes from 0 V to approximately 4.8 V at $10 \mu\text{V}$ input.
TOLERANCE $\pm 2 \mu\text{V}$
- G STEREO DECODER, MPX FILTERS.**
- 1 VCO
Connect a frequency counter and a 200 k ohm resistor in parallel between ground and TP 108.
 - 2 Set FM generator to $1000 \mu\text{V}$ output and no modulation.
 - 3 Adjust R 164 "MPX VCO" for a 19000 Hz reading on the counter.
TOLERANCE ± 100 Hz
 - 4 Disconnect frequency counter and resistor and depress FM NR defeat switch (in).
 - 5 Stereo switch threshold.
Modulate FM generator 1 kHz 100% left only plus 19 kHz pilot 8 - 10%.

- 6 Increase FM generator level upwards from 0 and adjust R 167 "ST SW" so that stereo light turns on and audio outputs, as watched on VTVM's and oscilloscope, switches to one channel only at 10 μ V input level.

TOLERANCE + 5 μ V

NOTE: When turning input level down the unit will switch into mono at a lower level, typically 7 μ V.

7 Stereo separation.

Set FM generator output to 1000 μ V, modulate left channel only.

- 8 Adjust R 158 for minimum on right channel VTVM.

- 9 Modulate FM generator right channel only and adjust R 158 for minimum on left channel VTVM.

- 10 If the minimum in step 8 and 9 are different, adjust R 158 so that the readings are the same in both channels.

SPECIFICATION better than 50 dB separation

11 MPX filter

Turn off audiomodulation, leaving pilot tone only. Disable IHF filter, or external 19 kHz filter.

- 12 Check 19/38 kHz suppression.

SPECIFICATION more than 60 dB

- 13 If unit does not meet specification adjust FL 102 "MPX FILTER" on left channel and FL 103 "MPX FILTER" on right channel to minimum output.

NOTE: DO NOT ADJUST THE MPX FILTERS UNLESS NECESSARY, the cores are brittle and break easily.

- 14 Release the FM NR DEFEAT switch (out).

H FM NR CIRCUIT

Confirm that FM NR switch is set to OFF position at first.

- 1 Feed from SG to the antenna input 125 μ V (300 ohms), 98.00 MHz with 100% stereo modulation, and set reference for S/N measurement.

With reference set, cancell the stereo modulation of 98.00 MHz and confirm that S/N ratio at this stage reads -60 dB approx.

- 2 Switch FM NR on, and adjust R-230 so that S/N is improved by 2 dB.

- 3 Switch FM NR off, and feed 40 μ V of 98.00 MHz with 100% stereo modulation to set reference for S/N.

Cancell stereo modulation and confirm that S/N at this stage reads -50 dB.

- 4 Switch FM NR on, and confirm that S/N ratio is improved by 5 - 13 dB.

I SYNTHESIZER FREQUENCY

- 1 Tune to a known accurate frequency source, i.e., broadcasting station or synthesized/digital display FM generator preferably in the midband 95 - 100 MHz.

- 2 Connect DMM across TP 104 (negative) and TP 105 (positive).

- 3 Adjust C 209 "FQ" so that DMM reads the same as recorded in E - 7.

TOLERANCE \pm 10 mV

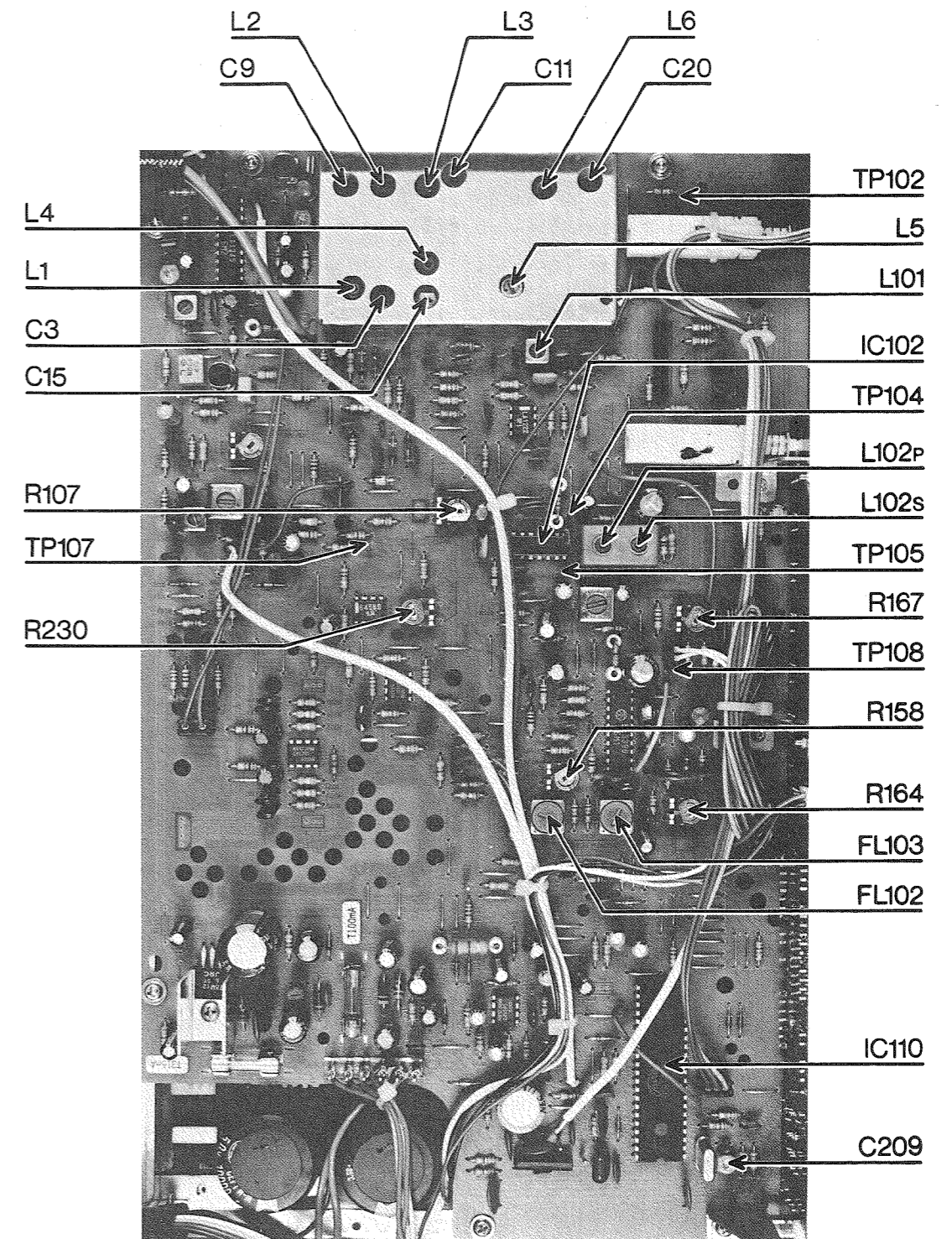

AM ALIGNMENTS

- A OSCILLATOR.**
- 1 Connect DMM to TP 101 and gnd.
 - 2 Tune to 1710 kHz. Enter into preset 1. Adjust C 148 for reading of $31 \pm 0.5\text{VDC}$.
 - 3 Tune to 520 kHz. Enter into preset 2. Adjust L 103 for reading of $1.8 \pm 0.1\text{ VDC}$.
 - 4 Repeat steps 2 and 3 until within tolerances.
- B ANTENNA, IF**
- 1 Swing antenna away from chassis and peel back label (if present) to expose adjustment tab.
 - 2 Connect DC voltmeter to centertap, R 208 and gnd.
 - 3 Tune to station of moderate strength, near 600 kHz. Enter into preset 3. Adjust L 951 (move tab under label on antenna) for maximum reading on meter. (Use non-interactive tool, such as plastic or wooden stick.)
 - 4 Adjust L 104 and L 106 for maximum reading on meter.
 - 5 Tune station of moderate strength near 1400 kHz. Enter into preset 4. Adjust C 147 for maximum reading on meter.
 - 6 Repeat steps 3 and 5 until no further improvement is seen.
- C 9 kHz, 10 kHz WHISTLE FILTERS**
- 1 Tune to quiet spot on the dial (a clear frequency)
 - 2 Connect audio osc. to base, Q 117 (isolate with 0.1 - 1.0 μF capa.)
 - 3 Connect AC VTVM (or scope) to TP 103.
 - 4 Set audio osc. to 10 kHz ($\pm 50\text{ Hz}$) 1 V. Adjust FL 104 for minimum meter reading.
 - 5 Set audio osc. to 9 kHz ($\pm 50\text{ Hz}$) 1 V. Adjust FL 105 for minimum meter reading.
- D SIGNAL METER, AUTO STOP**
- R 208 controls signal strength indication and auto stop level, adjust only if necessary, to correct for scan stopping on excessively weak signals, or failure to stop on moderately strong ones.
- NOTE: When finished, lock antenna bar adjustment with laquer (nail polish), re-install label.

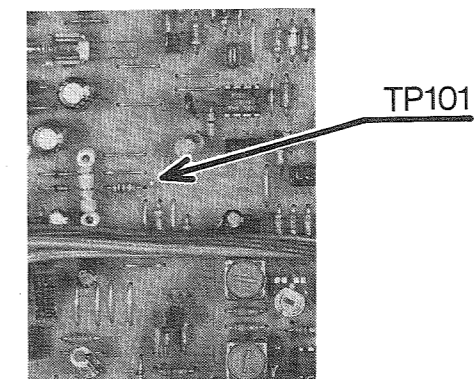
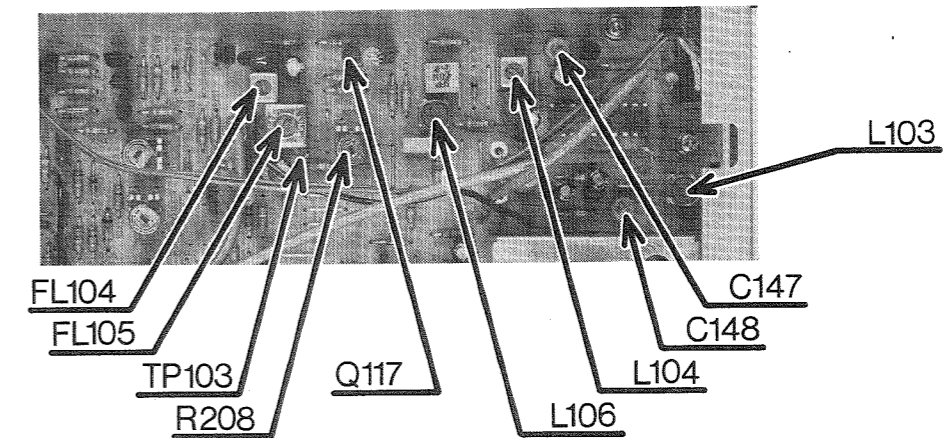
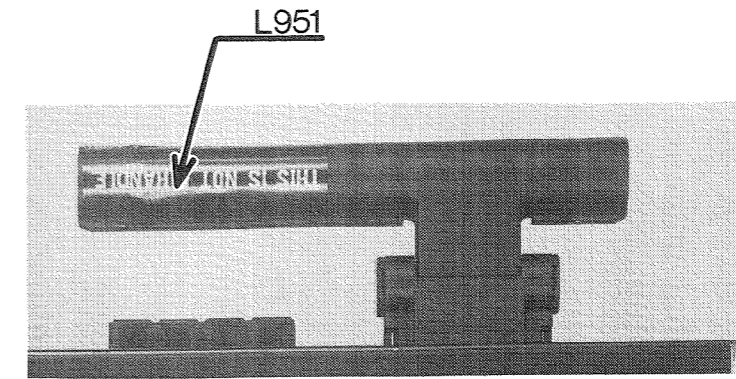

AMPLIFIER ALIGNMENTS

MEMO

A IDLE (QUIESCENT) CURRENT

- 1 Connect mV meter (DVM) from TP601 to TP602, left chan. (from TP 651 to TP652, right chan.)
- 2 Adjust R 624, left chan. (R 674, right chan.) so that meter reading is 20 - 25 mVDC.

NOTE: Reading may take a few minutes to stabilize; re-check after offset adjustment (next step.)

B OFFSET (CENTERING) VOLTAGE:

Adjust R 645, left (R 695, right) so that voltage at spkr. terminals is 0 ± 50 mVDC.

NOTE: Perform these adjustments with no load, volume minimum.

C MINIMUM DISTORTION

- 1 Connect distortion meter to the output terminal for speaker.
- 2 Feed 20 KHz from audio generator into "MAIN IN" and adjust its input level so that the output at the speaker terminal is 3 V (RMS) with no load.
- 3 Adjust R 618 (left channel) and R 668 (right channel) so that the distortion measured at the speaker output terminal will become minimum.

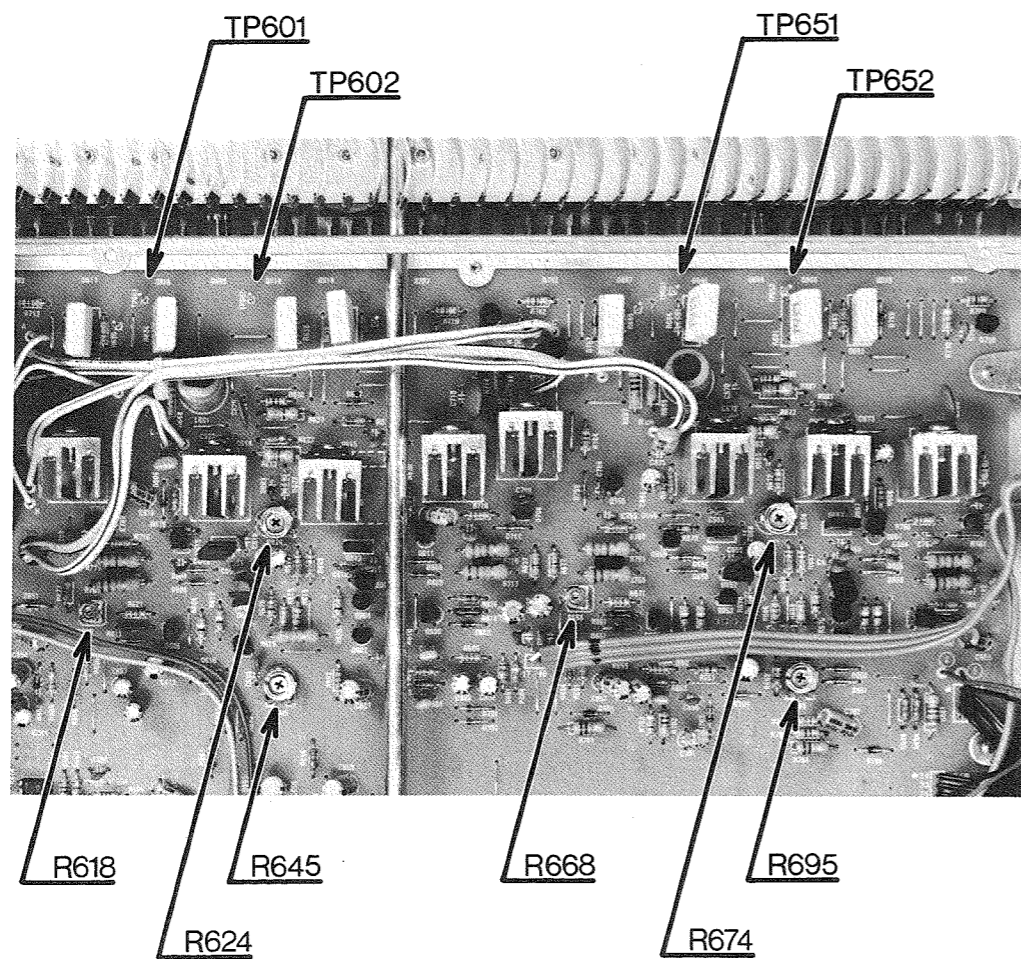

AMPLIFIER P.C.B. LAYOUT DIAGRAM

INPUT/OUTPUT PCB

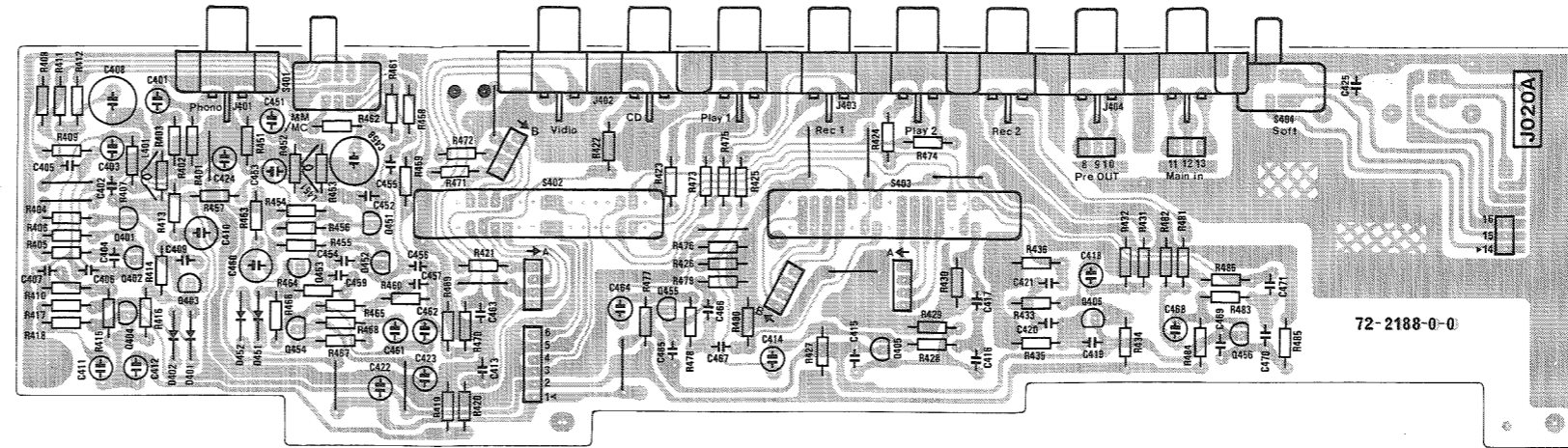

LED DISPLAY PCB



MAIN/CONTROL AMP. & POWER SUPPLY PCB

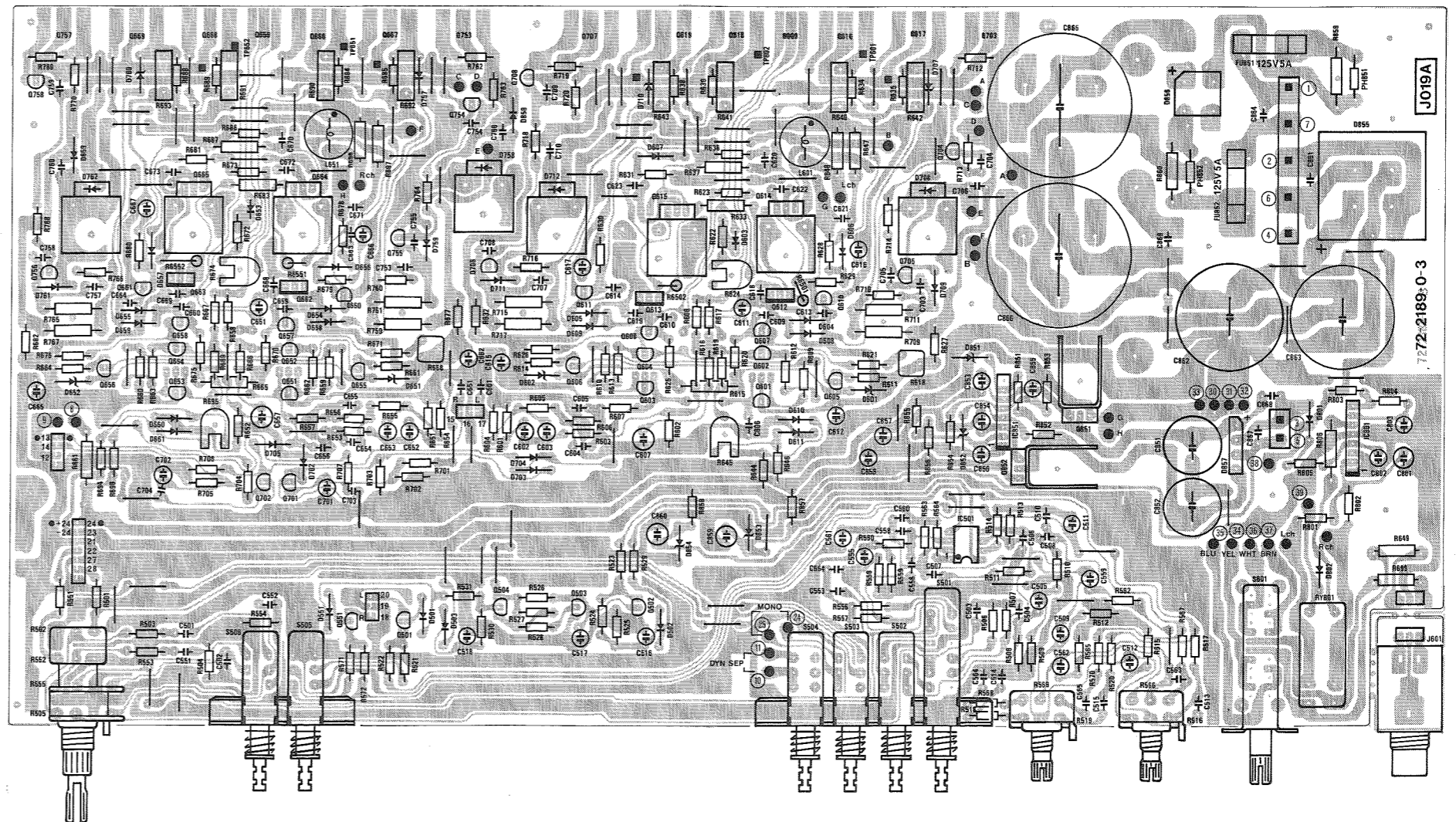

POWER SWITCH PCB

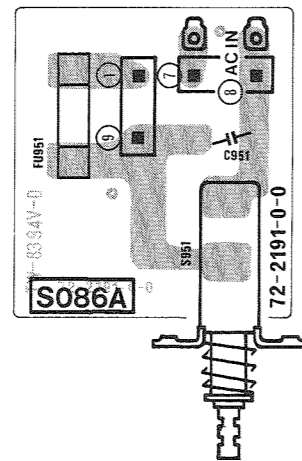

SCHEMATIC DIAGRAM NAD 7175PE AMPLIFIER SECTION

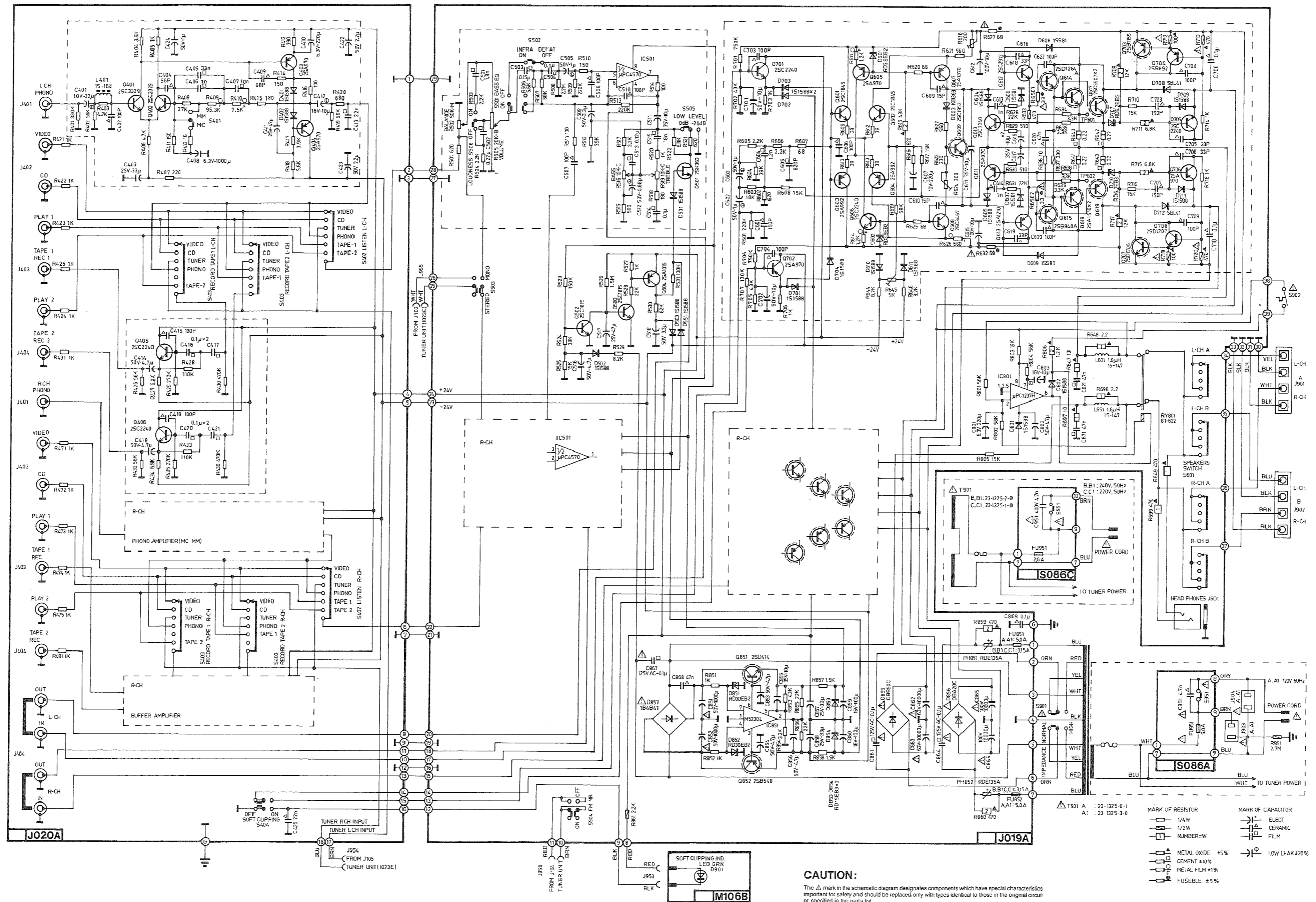

TUNER P.C.B. LAYOUT DIAGRAM

DISPLAY & PRESET SELECTOR PCB

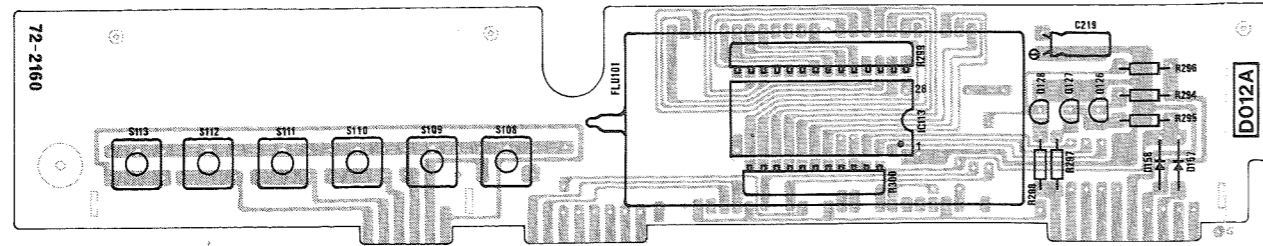

ANTENNA TERMINAL PCB

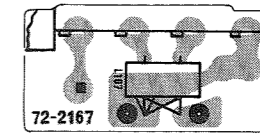

TUNER PCB

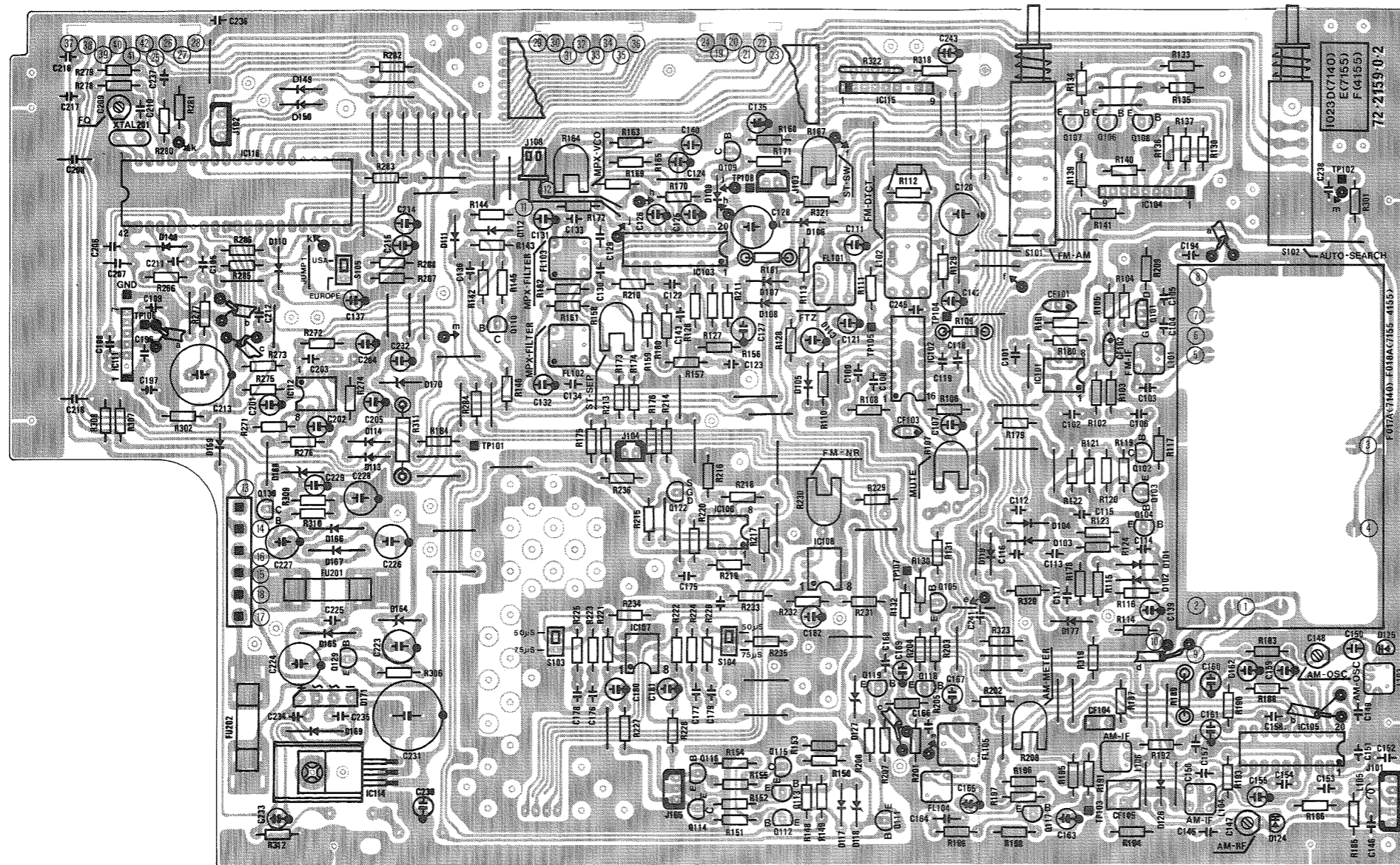

FRONTEND PCB

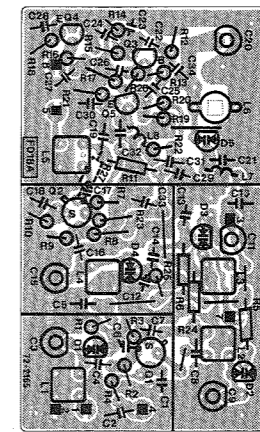

UP/DOWN PCB

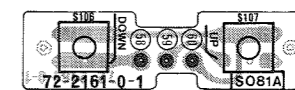

SCHEMATIC DIAGRAM NAD 7175PE TUNER SECTION

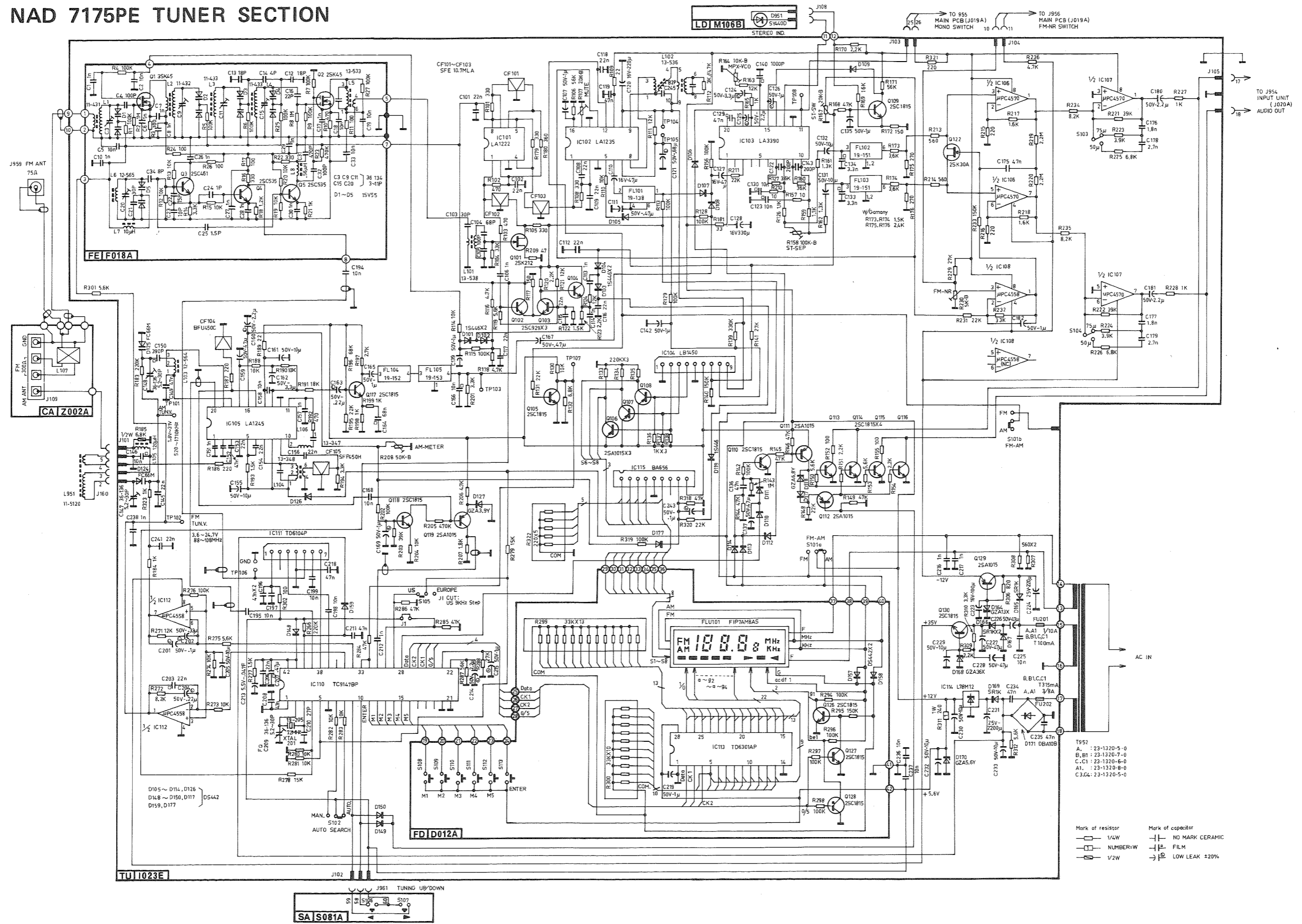

WIRING DIAGRAM

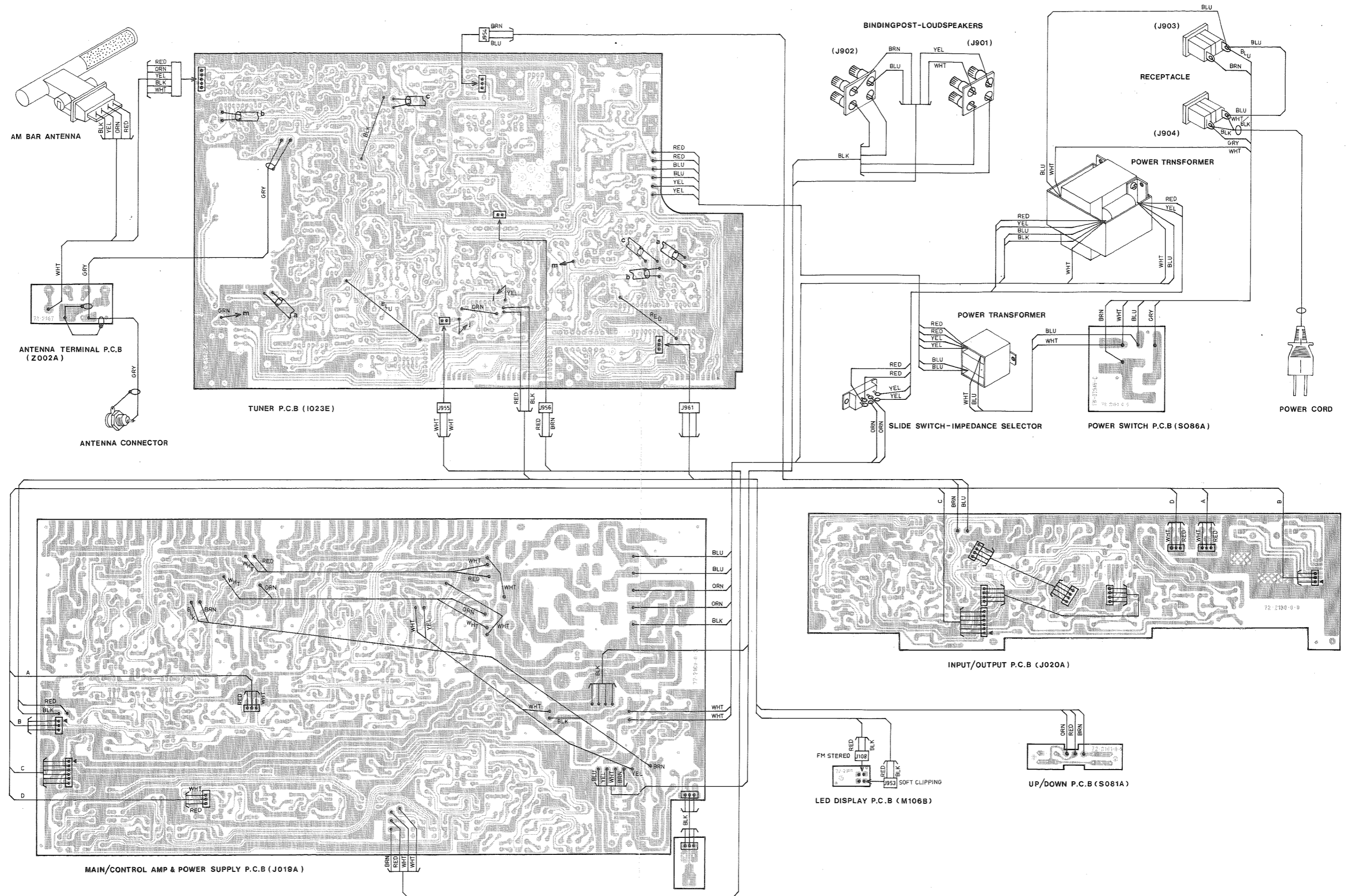

EXPLODED VIEW PARTS LIST

Ref. No.	Parts No.	Description
1	63-6272-1-0	FRONT PANEL
2	62-1105-0-0	PUSH BUTTON - SELECTORS
3	62-1105-1-0	PUSH BUTTON - ON/OFF
4	62-3465-0-0	PUSH BUTTON FRAME - SINGLE HOLE
5	62-3466-0-0	PUSH BUTTON FRAME - TWO HOLES
6	62-3468-0-0	PUSH BUTTON FRAME - FOUR HOLES
7	62-2317-0-0	ROTARY KNOB - TONE CONTROL/SELECTORS
8	62-2318-0-0	ROTARY KNOB - BALANCE
9	62-2319-0-0	ROTARY KNOB - VOLUME
10	62-3469-0-0	SUBPANEL
11	62-1106-0-0	PUSH BUTTON - BLACK
12	62-1106-1-0	PUSH BUTTON - LIGHT BROWN
13	62-1107-0-0	ROCKER BUTTON - UP/DOWN TUNE
14	62-1108-0-0	PUSH BUTTON - AUTO SEARCH
15	62-3471-0-0	PUSH BUTTON PLUNGER
16	88- 170-0-0	SPRING - PUSH BUTTON RETURN
17	63-5169-0-0	DISPLAY WINDOW
18	92-2103-0-0	FOOT - PLASTIC RIVET TYPE
19	63-1844-0-0	LABEL: THIS IS NOT A HANDLE
20	63-1845-0-0	PLATE (POLYESTER)
25	71-2584-0-1	FRONT SUBCHASSIS
26	71-2614-0-0	SIDE CHASSIS (L)
27	71-2587-0-0	SIDE CHASSIS (R)
28	71-2618-0-0	SUBCHASSIS (FRONT TO REAR SUPPORT)
29	71-2617-0-0	SUBCHASSIS (LEFT TO RIGHT SUPPORT)
30	92-1223-0-1	LOCKING PLATE - IMPEDANCE SWITCH
31	92-1225-0-0	INSULATOR (PVC) (A A1)
33	71-2615-0-1	REAR PANEL (A)
	71-2615-1-0	REAR PANEL (A1)
	71-2616-0-0	REAR PANEL (B B1 C C1)
34	71-3107-0-0	CABINET
35	71-3104-0-0	BOTTOM COVER
40	23-1325-0-1	POWER TRANSFORMER (A)
	23-1325-1-0	POWER TRANSFORMER (C C1)
	23-1325-2-0	POWER TRANSFORMER (B B1)
	23-1325-3-0	POWER TRANSFORMER (A1)
41	23-1320-5-0	TUNER POWER TRANSFORMER (A C3 C4)
	23-1320-6-0	TUNER POWER TRANSFORMER (C C1)
	23-1320-7-0	TUNER POWER TRANSFORMER (B B1)
	23-1320-8-0	TUNER POWER TRANSFORMER (A1)
42	85- 258-0-0	POWER CORD (A)
	85- 260-0-0	POWER CORD (A1)
	85- 240-0-0	POWER CORD (B)
	85- 259-0-0	POWER CORD (B1)
	85- 235-0-0	POWER CORD (C C1)
43	82-2178-0-0	RECEPTACLE (A A1)
44	81- 450-0-0	SLIDE SWITCH - IMPEDANCE SELECTOR (A B B1 C C1)
	81- 452-0-0	SLIDE SWITCH - IMPEDANCE SELECTOR (A1)
45	82-2162-0-0	F TYPE ANTENNA CONNECTOR (A A1)
	82- 293-0-0	DIN TYPE ANTENNA CONNECTOR (B B1 C C1)

Ref. No.	Parts No.	Description
46	65- 128-0-0	SHAFT - SELECTOR
47	62-3472-0-0	BUSHING FOR SHAFT SELECTOR
48	62-3474-0-0	JOINT FOR SHAFT SELECTOR
49	87-3242-0-0	GROUND TERMINAL
50	87-3246-0-0	STUD BOTTOM COVER SUPPORT
51	62-3332-0-0	BUSHING - AC POWER CORD
52	63-1843-0-0	LABEL (CAUTION FOR FUSE) (A A1)
53	74-3110-0-0	HEAT SINK
54	81-2333-0-0	PUSH SWITCH - ON/OFF
55	82- 118-0-0	JUMPER CONNECTOR
56	82-2164-0-0	BINDINGPOST - LOUDSPEAKERS
57	11-5120-0-0	AM BAR ANTENNA
58	RH-14	THERMAL SWITCH CLAMP
63	J020A	INPUT/OUTPUT PCB
63-1	82-2130-0-0	RCA CONNECTOR - SINGLE
63-2	82-2157-0-0	RCA CONNECTOR - DOUBLE
63-3	82-2159-0-0	RCA CONNECTOR - TRIPLE
63-4	81- 185-0-0	ROTARY SWITCH - RECORD SELECTOR
63-5	81- 187-0-0	ROTARY SWITCH - LISTEN SELECTOR
63-6	81- 447-0-0	SLIDE SWITCH - PHONO MM/MC SELECOTOR
64	J019A	MAIN/CONTROL AMP & POWER SUPPLY PCB
64-1	41- 685-0-0	ROTARY POTENTIOMETER - BASS & TREBLE
64-2	41- 688-0-0	ROTARY POTENTIOMETER - VOLUME
64-3	81- 188-0-0	ROTARY SWITCH -LOUDSPEAKER SELECTOR
64-4	74-3109-0-0	HEAT SINK
64-5	82-2169-0-0	HEADPHONE JACK
64-6	81-2337-0-0	FUNCTION SWITCH BANK (4 SWITCHES)
64-7	81-2338-0-0	FUNCTION SWITCH BANK (2 SWITCHES)
64-8	74-3105-0-0	HEAT SINK
65	S086A	POWER SWITCH PCB
66	M106B	LED DISPLAY PCB
67	F018A	FM FRONT-END PCB
68	I023E	TUNER PCB
68-1	81-2325-0-0	FUNCTION SWITCH - AUTO SEARCH & AM/FM SELECTOR
68-2	74- 388-0-0	HEAT SINK
68-3	71-1889-0-0	PCB SUPPORT
69	D012A	DISPLAY & PRE-SET SELECTOR PCB
69-1	7AM8AS	FLUORESCENT INDICATOR TUBE
69-2	81-2326-0-0	MOMENTARY SWITCH - PRE-SET & UP/DOWN
70	S081A	UP/DOWN PCB
71	Z002A	ANTENNA TERMINAL PCB
71-1	82-2163-0-0	CONNECTOR - ANTENNA TERMINAL
74		TAPPING SCREW (PHILLIPS HEAD 3×6 Cr)
75		TAPPING SCREW (PHILLIPS HEAD 3×8 Cr)
76		TAPPING SCREW (PHILLIPS HEAD 3×6 BLK)
77		TAPPING SCREW (PHILLIPS HEAD 3×8 BLK)
78		TAPPING SCREW (WASHER HEAD 3×6 Cr)
79		MACHINE SCREW S (WASHER HEAD 3×6 Cr)
80		MACHINE SCREW S (PHILLIPS HEAD 4×6 Cr)
81		MACHINE SCREW (PAN 3×6 Cr)
82		MACHINE SCREW (PHILLIPS HEAD 3×8 BLK)
83		NUT (HEXAGON M4-7-3.2 Cr)

EXPLODED VIEW

Ref. No.	Parts No.	Description
84		WASHER (PLAIN 4-10-0.8 Ni)
85		WASHER (TOOTHED LOCK B4 Ni)
86		WASHER (TOOTHED LOCK B3 Ni) (A A1)
87		RETAINING RING (E TYPE 5)
88		TERMAL LUG (3 Ni) (A A1)
89		TAPPING SCREW (PAN 2.6×6 Cr)
90		MACHINE SCREW (PHILLIPS HEAD 3×6 Cr)
91		CABINET SCREW WITH WASHER (4×6 BLK)
92		MACHINE SCREW (PHILLIPS HEAD 3×8 Cr)
93		LOCKING PLATE-HEAD PHONE JACK (HLJ0999-01-480)
94		TONE CONTROLS NUT (HEXAGON 7-11-2)
95		WASHER (PLAIN 7-12-0.5)
96		VOLUME CONTROL NUT (HEXAGON 9-11-2)
97		WASHER (PLAIN 9-14-0.5)
98		F-CONNECTOR NUT (HEXAGON UNF 3/8-11-2)
99		TERMINAL LUG (MET31-0107)

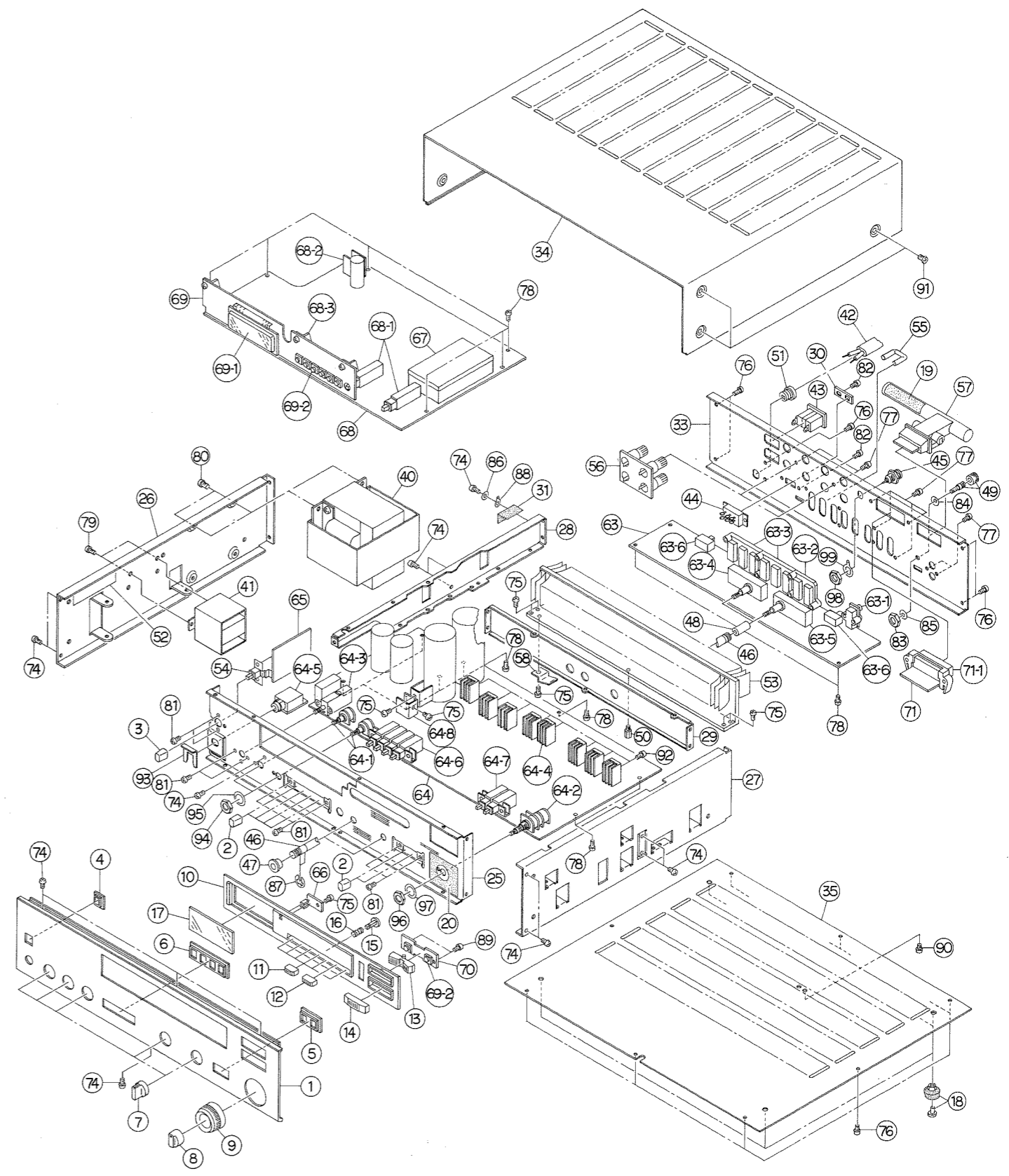

ELECTRICAL PARTS LIST

NOTE: This is not a complete electrical parts list.

INPUT/OUTPUT P.C.B.: J020A (EXPLODED VIEW REF. NO. 63)

SYMBOL NO.	PARTS NO.	DESCRIPTIONS
Q401, Q402, Q451, Q452	2SC3329	TRANSISTOR
Q403, Q404, Q453, Q454	2SA970	"
Q405, Q406, Q455, Q456	2SC2240	"
D401, D402, D451, D452	1S1588	DIODE
L401, L451	15-168	COIL 3.7mH
C401, C451	10V, 22 μ F	ELECTROLYTIC CAPACITOR LOW LEAKAGE
C412, C462	16V, 10 μ F	"
R409, R459	95.3K Ω , 1/4W	METAL FILM RESISTOR
R410, R460	7.5K Ω , 1/4W	"

MAIN/CONTROL AMP & POWER SUPPLY P.C.B.: J019A (EXPLODED VIEW REF. NO. 64)

SYMBOL NO.	PARTS NO.	DESCRIPTIONS
IC501	μ PC4570C	INTEGRATED CIRCUIT
IC801	μ PC1237H	"
IC851	M5230L	"
Q501, Q551	2SK363	TRANSISTOR
Q502, Q503	2SC1815	"
Q504	2SA1015	"
Q601, Q602, Q651, Q652	2SC1845	"
Q603, Q604, Q653, Q654	2SA992	"
Q605, Q611, Q655, Q661	2SA970	"
Q702, Q706, Q756		
Q606, Q610, Q656, Q660	2SC2240	"
Q701, Q705, Q755		
Q607, Q657	2SA1370	"
Q608, Q658	2SC3467	"
Q609, Q659	2SC1953	"
Q612, Q662	2SC2912	"
Q613, Q663	2SA1210	"
Q614, Q664	2SD1264D	"
Q615, Q665	2SB940A	"
Q616, Q617, Q666, Q667	2SC3907	"
Q618, Q619, Q668, Q669	2SA1516	"
Q703, Q753	2SB1155	"
Q707, Q757	2SD1706	"
Q704, Q754	2SB892	"
Q708, Q758	2SD1207	"
Q851	2SD414	"
Q852	2SB548	"
D501, D502, D503, D551	1S1588	DIODE
D604, D605, D610, D611		
D654, D655, D660, D661		
D702, D703, D704, D705		
D709, D711, D759, D761		
D801, D802		

SYMBOL NO.	PARTS NO.	DESCRIPTIONS
D601, D602, D651, D652	RD3.9EB2	DIODE
D603, D653	KB369	"
D606, D607, D608, D609	1SS81	"
D656, D657, D658, D659		
D707, D710, D757, D760	RD6.2EB3	"
D708, D712, D758, D762	5BL41	"
D851, D852	RD30EB2	"
D853, D854	RD15EB3	"
D855	DBB50CK15	"
D856	DBA20CK15	"
D857	1B4B41	"
L601, L651	15-147	COIL 1.6 μ H
C505, C555, C602, C603	50V, 1 μ F	ELECTROLYTIC CAPACITOR LOW LEAKAGE
C652, C653		
C512, C562	50V, 0.68 μ F	"
C803	16V, 10 μ F	"
C851, C852	50V, 1000 μ F	ELECTROLYTIC CAPACITOR
C862, C863	63V, 10000 μ F	"
C865, C866	100V, 10000 μ F	"
R611, R614, R661, R664	1.21K Ω , 1/4W	METAL FILM RESISTOR
R615, R665	43K Ω , 2W	OXIDE METAL RESISTOR
R618, R668	41-7106, 200 Ω	VARIABLE RESISTOR
R624, R674	41-782, 300 Ω	"
R626, R676	680 Ω , 1/4W	METAL FILM RESISTOR
R627, R632, R677, R682	68 Ω , 1/4W	FUSIBLE RESISTOR
R640, R641, R642, R643	0.22 Ω , 3W	CEMENTED WIREWOUND RESISTOR
R690, R691, R692, R693		
R645, R695	41-787	VARIABLE RESISTOR 5K Ω
R647, R697	10 Ω , 1W	OXIDE METAL RESISTOR
R648, R698	2.2 Ω , 1W	"
R649, R699	470 Ω , 1W	"
R709, R717, R759, R769	12K Ω , 2W	"
R711, R715, R761, R765	6.8K Ω , 2W	"
R712, R719, R762, R769	100 Ω , 1/2W	"
R713, R720, R763, R770	470 Ω , 1/2W	"
R806	1.2K Ω , 2W	"
R859, R860	470 Ω , 2W	"
R6501, R6502, R6551, R6552	33 Ω , 1/4W	FUSIBLE RESISTOR
PH851, PH852	RDE135A	P.T.C.
RY801	81-622, MR72	RELAY
FU851, FU852	5TT5	FUSE (A, A1) 125V, 5A
	5ST3.15	FUSE (B, C) 250V, 3, 15A
S902	81-7005	THERMOSTAT 110 $^{\circ}$ C

POWER SWITCH P.C.B.: S086A (EXPLODED VIEW REF. NO. 65)

SYMBOL NO.	PARTS NO.	DESCRIPTIONS
FU951	5TT5	FUSE (A, A1) 125V, 5A
	5ST2	FUSE (B, C) 250V, 2A

LED DISPLAY P.C.B.: M016B (EXPLODED VIEW REF. NO. 66)

SYMBOL NO.	PARTS NO.	DESCRIPTIONS
D951	SY440D	LED, FM STEREO
D952	SG240D	LED, SOFT CLIPPING

FM FRONT-END P.C.B.: F018A (EXPLODED VIEW REF. NO. 67)

SYMBOL NO.	PARTS NO.	DESCRIPTIONS
Q1, Q2	3SK45	TRANSISTOR
Q3	2SC461	"
Q4, Q5	2SC535	"
D1 ~ D5	1SV55	DIODE, VARIABLE CAPACITANCE
L1	11-431	FM ANTENNA COIL
L2	11-432	FM RF COIL
L3, L4	11-433	"
L5	13-533	IFT COIL
L6	12-565	OSC COIL
L7	10 μ H	CHOKE COIL
L8	0.56 μ H	"
C3, C8, C11, C15, C20	36-134	TRIMMER CAPACITOR, 3 ~ 11pF

TUNER P.C.B.: I023E (EXPLODED VIEW REF. NO. 68)

SYMBOL NO.	PARTS NO.	DESCRIPTION
IC101	LA1222	INTEGRATED CIRCUIT
IC102	LA1235	"
IC103	LA3390	"
IC104	LB1450	"
IC105	LA1245	"
IC106, IC107	uPC4570	"
IC108, IC112	uPC4558	"
IC110	TC9147BP	"
IC111	TD6104P	"
IC114	L78M12	"
IC115	BA656	"
Q101	2SK212	TRANSISTOR
Q102, Q103, Q104	2SC929	"
Q105, Q109, Q110, Q113	2SC1815	"
Q114, Q115, Q116, Q117		
Q118, Q130		
Q106, Q107, Q108, Q111	2SA1015	"
Q112, Q119, Q129		
Q122	2SK30A	"

SYMBOL NO.	PARTS NO.	DESCRIPTION
D101, D102, D103, D104 D119	1S446	DIODE
D105 ~ D114, D117, D126 D148 ~ D150, D159, D177	DS442BT	"
D118	GZA6.8Y	"
D124, D125	FC66M	"
D127	GZA3.9Y	"
D164	GZA13X	"
D165, D166, D167, D169	SR-1K	"
D168	GZA36X	"
D170	GZA5.6Y	"
D171	DBA10B	"
L101	13-538	IFT COIL
L102	13-536	FM DETECTOR COIL
L103	12-564	AM OSC COIL
L104	13-348	450KHz MATCHING COIL
L105	15-167	CHOKE COIL, 120 μ H
L106	13-347	IFT COIL
C147, C148, C209	36-136	TRIMMER CAPACITOR, 5.2~30pF
C121	50V, 0.68 μ F	ELECTROLYTIC CAPACITOR LOW LEAKAGE
C124	50V, 3.3 μ F	"
C125, C160, C214	50V, 2.2 μ F	"
C126, C169, C215	50V, 1 μ F	"
C163, C204	50V, 0.22 μ F	"
C201	50V, 0.33 μ F	"
C202, C243	50V, 0.1 μ F	"
C213	5.5V, 0.047 μ F	MEMORY BACKUP CAPACITOR
R107, R167	41-789	VARIABLE RESISTOR, 20K Ω B
R158	41-792	" , 100K Ω B
R164	41-788	" , 10K Ω B
R208	41-791	" , 50K Ω B
R230	41-787	" , 5K Ω B
R322	200K Ω x5	RESISTOR ARRAY
CF101, CF102, CF103	19-155	CERAMIC FILTER(C1)
"	19-154	" (A,A1,B,C)
CF104	19-136	"
CF105	19-140	"
FL101	19-138	ANTIBIRDIE FILTER
FL102, FL103	19-151	LOW PASS FILTER
FL104	19-152	"
FL105	19-153	"
XTAL201	19-205	CRYSTAL, 7.2MHz
FU201	MDL1/10A	FUSE(A,A1),250V, 1/10A
"	100mA	FUSE(B,C),250V, 100mA
FU202	MDL3/8A	FUSE(A,A1),250V, 3/8A
"	315mA	FUSE(B,C),250V, 315mA

SERVICE MANUAL

DISPLAY & PRE-SET SELECTOR P.C.B.: D012A (EXPLODED VIEW REF. NO. 69)

SYMBOL NO.	PARTS NO.	DESCRIPTION
IC113	TD6301AP	INTEGRATED CIRCUIT
Q126, Q127, Q128	2SC1815	TRANSISTOR
D157, D158	DS442	DIODE
R299 R300	33K Ω \times 13 33K Ω \times 10	RESISTOR ARRAY "
FLU101	7AM8AS	FL INDICATOR

ANTENNA TERMINAL P.C.B.: Z002A (EXPLODED VIEW REF. NO. 71)

SYMBOL NO.	PARTS NO.	DESCRIPTION
L107	11-419	BALUN TRANSFORMER

© 1986 BY NAD 369 PRINTED IN JAPAN

7175PE
AM/FM RECEIVER

NAD ELECTRONICS
BOSTON/LONDON